



TESAN F001-05
June 15, 2005

TECHNICAL ENGINEERING SUPPORT APPLICATION NOTICE (TESAN)

SUBJECT: PS-12/24-8CP or MP for use in the City of Chicago

Introduction

This document discusses the use of PS-12/24-8CP/MP power supplies when used in the City of Chicago. This document will describe 1) the requirements of the City of Chicago as they relate to remote power supplies, 2) the benefits of using remote power supplies, and 3) how to connect the PS-12/24-8CP/MP power supplies to fire alarm control panels (FACP) for use in the City of Chicago.

Policies and Rules of the City of Chicago

On June 2, 2005, the Department of Construction and Permits issued a new 'Policy and Rule' titled *Remote Power Supply Control Unit -- Fire Alarm System*. The policy states:

"Remote power supplies or the power boosters can be utilized to expand the power capability of a fire alarm control panel for notification appliance circuits (NAC). The NAC remote power supply units shall be UL listed and shall meet all the installation requirements of NFPA-72 and Article 760 of the Chicago Municipal Code.

The NAC power supply shall be monitored and activated from the addressable fire alarm loop, and shall not be activated from the notification appliance output of the fire alarm panel. They shall also comply with the following requirements:

1. The NAC power supply control unit shall be connected and controlled on a class "A" addressable fire alarm system loop.
2. The NAC power supply control unit shall contain self-diagnosing circuitry to alert the fire control panel when a fault or trouble condition occurs.
3. The power control unit's output circuits can be class "B" with an end of line resistor or Class "A", loop out and back to the unit.

This new policy of NAC power supply acceptance shall apply to the existing as well as new fire alarm systems. The fire alarm systems can now be expanded without excessive cost to the building owners."

To view this memo on line, go to the City of Chicago's website (www.cityofchicago.org) and click on the following series of hyperlinks: City Departments > DCAP: Department of Construction and Permits > Policies and Rules > Remote Power Supply Control Unit -- Fire Alarm System.

Benefits of using Remote Power Supplies

Remotely mounting NAC power supplies benefits the building operation, the installer, and the end-user. Some of those benefits include:

Operational Benefits

- The fire alarm system monitors and controls the PS-12/24-8CP/MP via addressable devices on a class "A" loop
- The PS-12/24-8CP/MP self-diagnosing circuitry alerts the fire control panel when a fault or trouble condition occurs
- The PS-12/24-8CP/MP can be used with and connected to any UL Listed and/or FM Approved fire alarm control panel
- The PS-12/24-8CP/MP meets all applicable requirements of NFPA 72
- The PS-12/24-8CP/MP's output circuits operate in class B (with an end of line resistor) mode or class A (loop out and back) mode
- Failure of one of five PS-12/24-8CP/MP's circuit or the unit itself, will not affect the operation of any of the other circuits or any of the other power supplies in the building
- The alarm and trouble conditions of the PS-12/24-8CP/MP will display in English at the first-floor fire department LCD display unit

Installer Benefits

- The PS-12/24-8CP/MP can be integrated and controlled via a class "A" addressable fire alarm system loop
- The number of PS-12/24-8CP/MPs used in a system is dependent only on the number of monitor and control points allowed by the fire alarm control panel
- When remotely mounting the PS-12/24-8CP/MP, the number of supervised class A or B notification appliance circuits available on every floor of the building is only limited by the number of addresses available on the FACP
- This reduces the cost of the systems installation and possible failure points
- Installing the system requires less wiring to be run from the first-floor fire alarm control to the upper floors thus reducing the number of wires in the riser feed
- The PS-12/24-8CP/MP latches on its trouble LEDs for OUT1, OUT2, OUT3, OUT4 and, GND FAULT when the trouble occurs on the respective circuit. The LEDs turn OFF when an alarm condition occurs or when the PS-12/24-8CP/MP system reset switch (SW8) is pressed.
- The trouble relay follows any trouble condition and is not latching.
- The combined operation of the previous two bullet points allows the end-user to see what condition the PS-12/24-8CP/MP is currently at while maintaining the location of the trouble until the service personal can investigate the wiring problem.

End-User Benefits

- Reduces the cost of the systems installation and possible failure points.
- Designed for quality by American engineers
- Proudly assembled by union workers in Long Branch, NJ.

Connecting Wheelock Power Supplies to Fire Alarm Control Panel in the City of Chicago

All Applications

The FACP connects to the PS-12/24-8CP/MP the same way for all applications – through an addressable SLC. The devices needed to trigger the power supply can either be addressable dry contact modules or addressable 24VDC modules. The connections to those types of devices are as follows:

1. Dry Contact Initiating Module

- The dry contact initiating devices are connected to the DRY1 C and DRY1 NC terminals as in Figure 1. The dry contacts need to be normally open devices that are held closed until alarm. To activate the power supply, open the contacts.
- The monitoring device needs to be connected to Common Trouble Output the C and NC terminals of the PS-12/24-8CP/MP as in Figure 1.

NOTE: When the DRY1 and DRY2 terminals are not in use, a jumper must be connected across them.

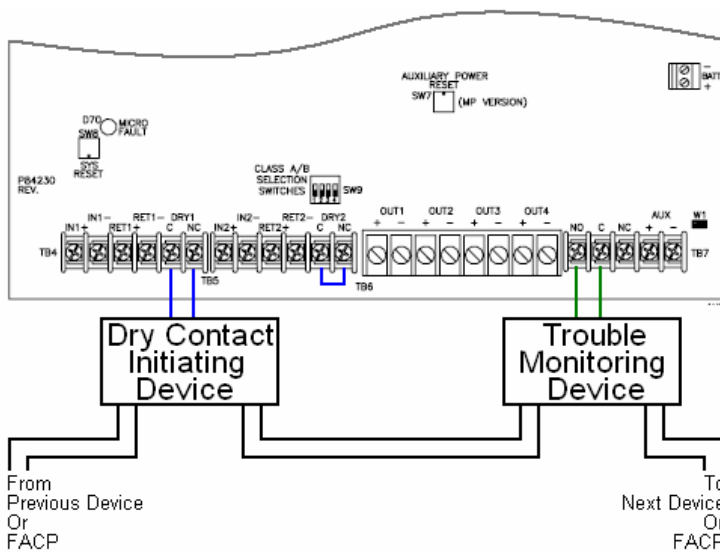

Figure 1

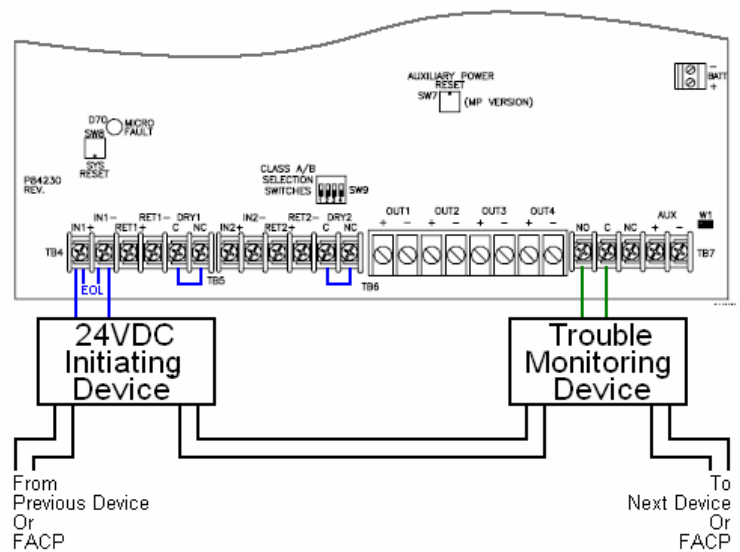

Figure 2

2. 24VDC Initiating Modules– Separate Trouble Reporting

- The 24VDC initiating devices are connected to IN+ and IN- terminals as in Figure 2.
- The EOL device needed for many of these types of modules needs to be connected across the IN+ and IN- terminals as well, see Figure 2. Do not connect the EOL device across the RET+ and RET- terminals.
- A jumper must be connected across the DRY1 and DRY2 terminals.
- The monitoring device needs to be connected to Common Trouble Output the C and NC terminals of the PS-12/24-8CP/MP as in Figure 2.

Application 1: Fire Detection Devices Located on All Floors

Figure 3 shows a series of PS-12/24-8CP/MPs in a building that is protected by detectors. When detection devices are located on all floors of the building, a separate Class A loop of addressable devices will feed each floor. Each floor would have its own PS-12/24-8CP/MP that would be controlled by an addressable initiating device and would be monitored by an addressable monitoring device.

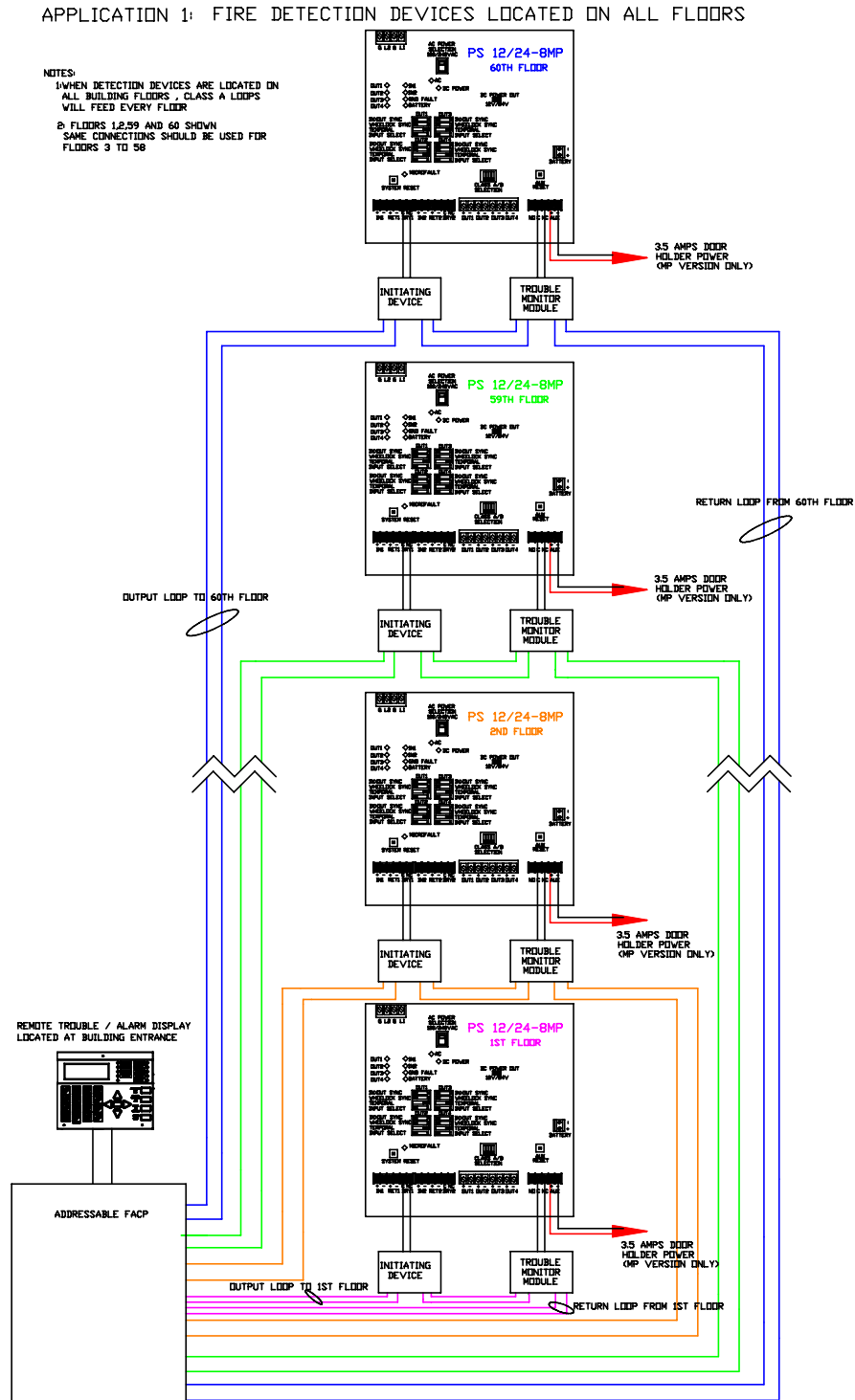

Figure 3

Application 2: Building is covered by Sprinklers Only

Figure 4 shows a series of PS-12/24-8CP/MPs in a building that is protected by sprinklers only. When only sprinklers protect the building, a Class A loop of addressable devices will feed the entire building. Again each floor would have its own PS-12/24-8CP/MP that would be controlled by an addressable initiating device and would be monitored by an addressable monitoring device.

APPLICATION 2: BUILDING IS COVERED BY SPRINKLERS ONLY

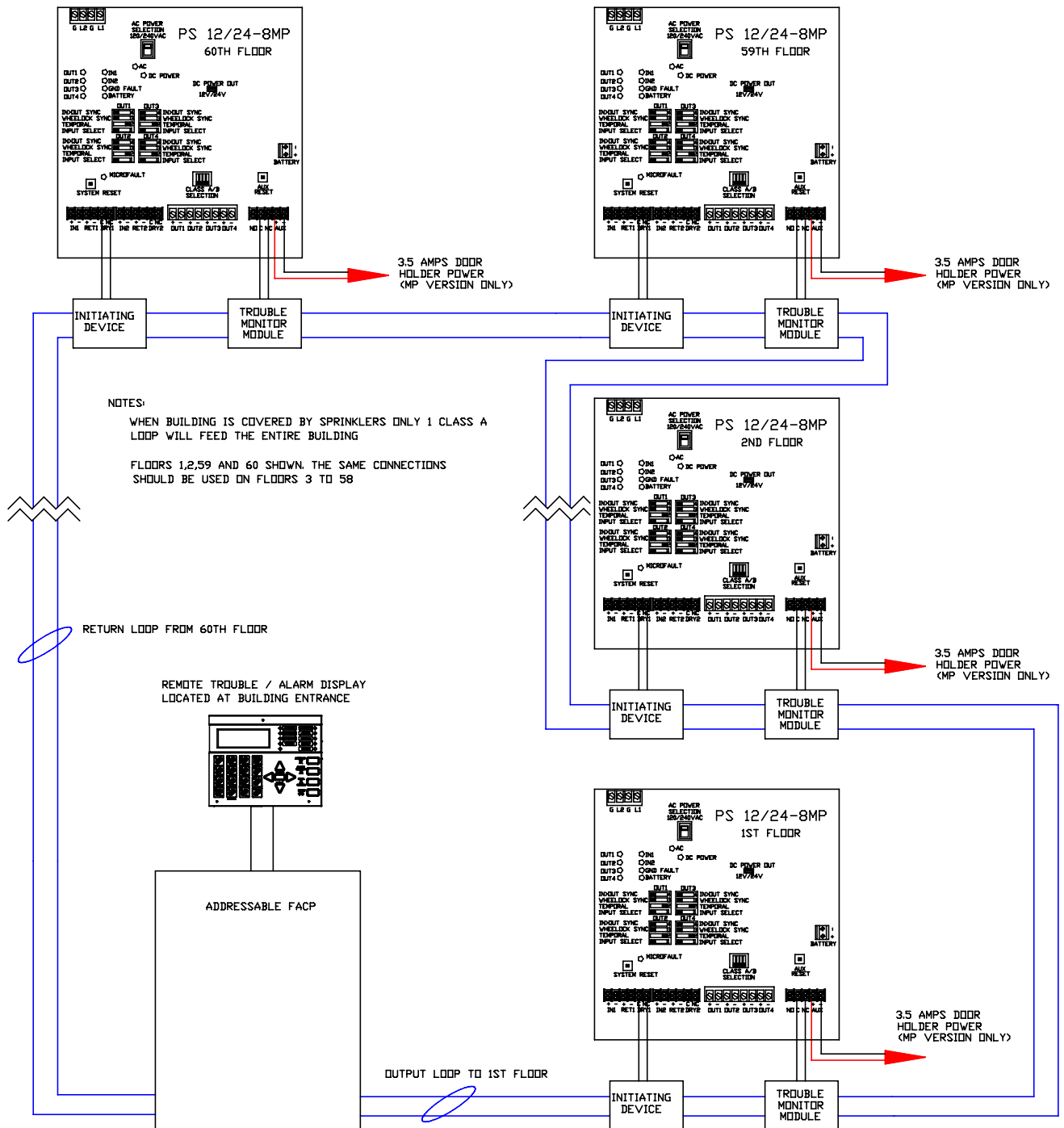

Figure 4